

American National Standard

Test Procedure and Acceptance Criteria for – Physical Endurance for Steel Doors, Frames and Frame Anchors



Standards As Tough As Steel.™

SPONSOR

Steel Door Institute

Approved June 10, 2011



American National Standard
Test Procedure and Acceptance Criteria for –
Physical Endurance for
Steel Doors, Frames and Frame Anchors

Secretariat
Steel Door Institute

Approved June 10, 2011

American National Standards Institute, Inc.

American National Standard

Approval of an American National Standard requires verification by ANSI that the requirements for due process, consensus, and other criteria for approval have been met by the standards developer.

Consensus is established when, in the judgement of the ANSI Board of Standards Review, substantial agreement has been reached by directly and materially affected interests. Substantial agreement means much more than a simple majority, but not necessarily unanimity. Consensus requires that all views and objections be considered, and that a concerted effort be made toward their resolution.

The use of American National Standards is completely voluntary; their existence does not in any respect preclude anyone, whether they have approved the standards or not, from manufacturing, marketing, purchasing, or using products, processes, or procedures not conforming to the standards.

The American National Standards Institute does not develop standards and will in no circumstances give any interpretation of any American National Standard. Moreover, no person shall have the right or authority to issue an interpretation of an American National Standard in the name of the American National Standards Institute. Requests for interpretations should be addressed to the secretariat or sponsor whose name appears on the title page of this standard.

CAUTION NOTICE: This American National Standard may be revised or withdrawn at any time. The procedures of the American National Standards Institute require that action be taken periodically to reaffirm, revise, or withdraw this standard. Purchasers of American National Standards may receive current information on all standards by calling or writing the American National Standards Institute.

Published by

Steel Door Institute
30200 Detroit Road, Cleveland, Ohio 44145-1967

Copyright © 2011 by Steel Door Institute
All rights reserved.

No part of this publication may be reproduced in any form, in an electronic retrieval system or otherwise, without prior written permission of the publisher.

Printed in the United States of America

ANSI/SDI A250.4-2011

Contents

Page

Foreword	ii
1 Purpose	1
1.1 Reference documents.....	1
2 Apparatus and equipment	1
2.1 Door opener	1
2.2 Hardware.....	1
3 Preparation for test.....	2
4 Test specimen	2
4.1 Doors	2
4.2 Frames	2
5 Swing test.....	3
5.1 Doors	3
5.2 Frame.....	3
6 Twist test	4
7 Acceptance criteria	4
7.1 Doors	4
7.2 Frames	5
Figures	
1 Swing Test Detail.....	2
1A Swing Test Detail.....	3
2 Twist Test	4
Performance Reports	
Swing Test Form 1	6
Swing Test Form 2	7
Twist Test Form 3	8

Foreword (This Foreword is not part of American National Standard A250.4-2011)

The material contained in this document has been developed under the auspices of the Technical Committee of the Steel Door Institute.

The original standard was issued on July 28, 1980 and was revised in 1987, 1994 and 2001. The current edition is a revision of the 2001 document with the contents being updated to reflect changes that have taken place in the steel door and frame industry since that time.

Suggestions for improvement gained in the use of this standard are welcome, and should be sent to the Steel Door Institute, 30200 Detroit Road, Cleveland, Ohio 44145-1967.

The organizations which approved this standard and are part of the Accredited Standards Committee A250 formed February 8, 1991, are as follows:

- American Institute of Architects
- Builders Hardware Manufacturers Association
- Canadian Steel Door Manufacturers Association
- Cedar Valley Associates
- Door and Hardware Institute
- FM Approvals
- HMMA/Division of NAAMM
- Intertek Testing Services
- Steel Door Institute
- Therma-Tru
- Underwriters Laboratories Inc.

The Technical Committee of the Steel Door Institute, which developed this standard, had the following personnel at the time of approval:

- Terry Simpson, Chairman
- Claus Heide, Vice Chairman
- J. Jeffery Wherry, Managing Director

<i>Organization Represented</i>	<i>Name of Representative</i>
Amweld Building Products, Inc.	Mike Kolovich
Ceco Door Products.....	Tom Janicak
Curries Company	Dave Dedic
Deansteel Manufacturing Company.....	Claus Heide
Door Components.....	Tom Popow
Mesker Door Company	Mike Torres
Metal Products, Inc.	Tom Stone
Pioneer Industries.....	Kamal Sheikh
Republic	Jason Lisewski
Security Metal Products Corporation.....	Terry Simpson
Steelcraft	Kurt Roeper

American National Standard

Test Procedure and Acceptance Criteria for – Physical Endurance for Steel Doors, Frames and Frame Anchors

1 Purpose

The primary purpose of this procedure shall be to establish a standard method of testing the performance of a steel door mounted in a hollow metal or channel iron frame installed with appropriate anchors, under conditions that might reasonably be considered an accelerated field operating condition.

The user of this performance standard must temper his usage with the knowledge that there are many variables that affect door and frame performance, such as different hardware, anchors, glass and louver cutouts, field modification by parties other than the manufacturer, environmental factors, such as heat, cold, moisture, etc.

1.1 Reference documents

ANSI/BHMA A156.1-2006 *Butts and Hinges*

ANSI/BHMA A156.3-2008 *Exit Devices*

ANSI/BHMA A156.4-2008 *Door Controls – Closers*

ANSI/BHMA A156.7-2009 *Template Hinge Dimensions*

2 Apparatus and equipment

The apparatus and equipment used shall be the same when testing doors or frames with frame anchors. The main testing structure shall be constructed as shown in figures 1 and 2. The structure shall conform to the parts shown, except the opening width and height are permitted to vary to allow the testing of various door sizes. The test frame for

testing door or frame shall be anchored in such a manner as to ensure rigidity.

The swinging mechanism shall be in two parts:

2.1 Door opener

The door opener shall be an air motor positioned at 65° to the plane of the door in its closed position that will actuate an exit device mounted on the test door. The contact point shall be set to push the door open 60° ± 5°, and retract to allow the door closer to bring the door back into its original closed position and then begin the cycle again. See the specifications in figures 1 and 1A.

2.2 Hardware

The exit device, door closer and hinges used in testing shall be selected based on the manufacturer's recommendations for the testing level described in Swing Test Form 1. The manufacturer and model number shall be recorded in the report. All hardware shall be applied to the door and frame with fasteners provided by the hardware manufacturer (for example, machine screws or sex bolts) in the location recommended by the door manufacturer. The hardware shall conform to the latest editions of American National Standards ANSI/BHMA A156.1, 3, 4 and 7. The device shall be set to close the door at a rate of 15 cycles, ± 1, per minute.

Inspect all hardware and silencers at regular intervals, and adjust or replace as necessary. It is acceptable to apply lubrication to hinges and exit devices.

Note: Where the applicable BHMA Test Standards have been followed, this information shall be recorded in the test report.

3 Preparation for test

The door shall be hung in the frame on the hinges. Care shall be taken to ensure the hinges are properly applied to the door and frame as recommended by the hinge manufacturer, and any hinge fillers or shims, are in place. The clearance between the door and the frame shall be recorded in the test report.

The door frame shall be securely fastened to the test frame opening structure in accordance with the manufacturer's instructions. The manufacturer is permitted to select anchors for specific wall applications (i.e., wood stud anchors or steel stud anchors, loose or welded in or existing masonry wall anchors).

Silencers shall be installed on the frame and the stop face of the door shall contact the silencers. The frame shall be plumb, square, and rigid.

When applicable, wall surface materials (e.g., dry-wall) shall be applied to the test frame opening at

the frame throat to simulate actual construction conditions.

4 Test specimen

4.1 Doors

Unless specified otherwise, the test shall be performed on a 3'-0" x 7'-0" nominal size door. A detailed description of the construction of the door and the applicable processes such as welding, bonding, etc., used for attaching components, shall be recorded in the test report, Swing Test Form 1, under the "remarks" section.

4.2 Frames

Unless specified otherwise, the test shall be performed on a 3'-0" x 7'-0" nominal size frame having a 5 3/4" jamb depth. A detailed description of the door frame which shall cover all components used in the frame's construction, as well as applicable processes (such as welding, etc.) used for attaching and connecting components, shall be recorded

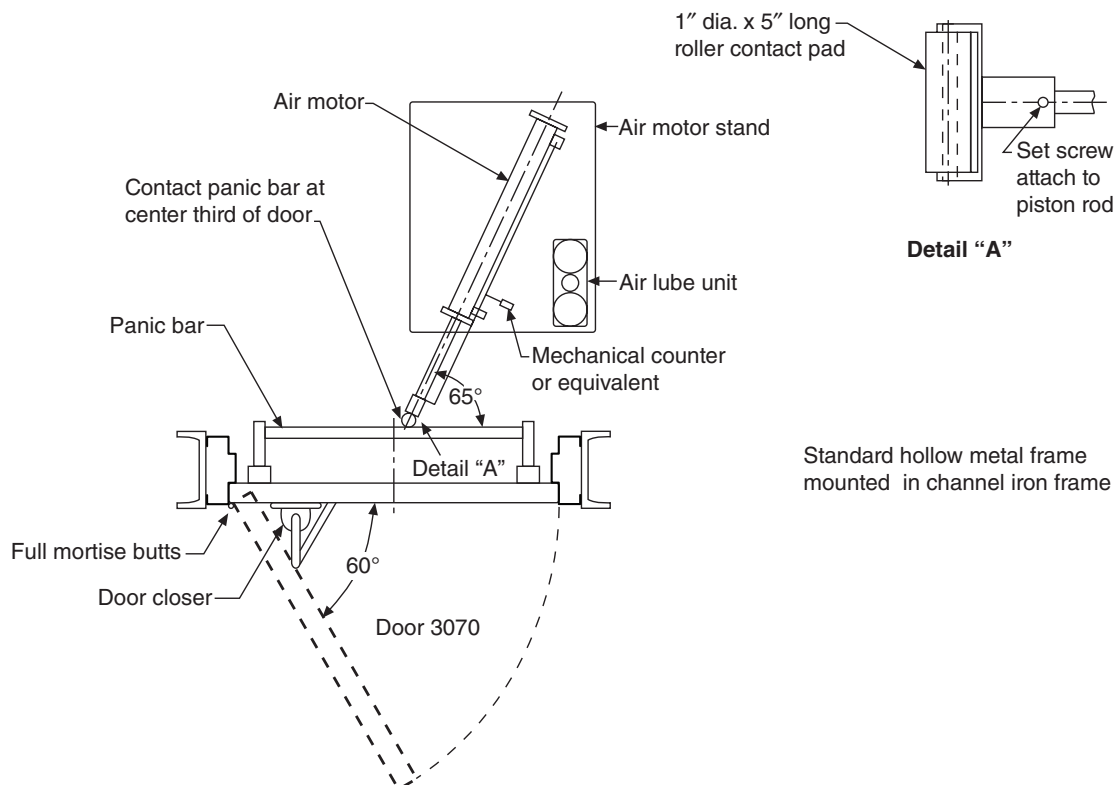

Figure 1 – Swing test detail

in the test report, Swing Test Form 2, under the "remarks" section.

A detailed description of the frame and anchoring system which shall cover all details of the anchors, as well as the means of attachment in the frame and the weight of the door used for the test shall be recorded in the test report, Swing Test Form 2.

5 Swing test

5.1 Doors

Duration of the test shall be 250,000 cycles with latching for Level C doors; 500,000 cycles with latching for Level B doors; and 1,000,000 cycles with latching for Level A doors. A general inspection of the door shall be made at 25,000 cycle intervals for the first 100,000 cycles and at 50,000 cycles thereafter. A mechanical counter or equivalent shall be used to record the cycles.

The general inspection shall cover perimeter clearances between door and frame and all compo-

nents readily accessible, such as face skins, exposed hinge and lock stiles, flush closing channels, end closures, hinge reinforcements, and lock body/face plate reinforcements and shall cover the integrity of assembly methods used to connect the door components.

Doors which have passed the cycling criteria at one level shall be deemed to have passed all lower levels. The results shall be recorded on a standard performance report, Swing Test Form 1.

5.2 Frame

Duration of the test shall be 250,000 cycles for Level C frames; 500,000 cycles for Level B frames; and 1,000,000 cycles for Level A frames. A general inspection of the frame shall be made at 25,000 cycle intervals for the first 100,000 cycles and at 50,000 cycle intervals thereafter.

The general inspection shall cover perimeter clearances between door and frame and all frame components readily accessible, such as corner

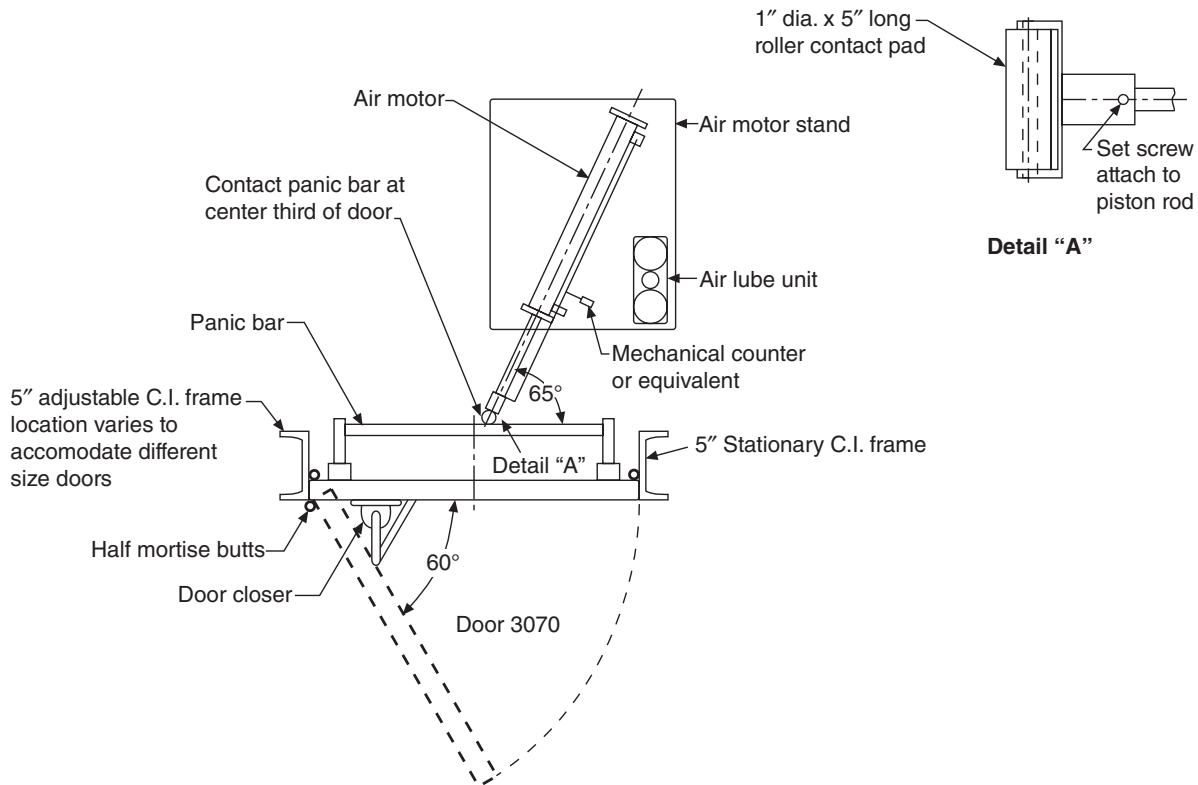

Figure 1A – Swing test detail

Door can be tested in channel iron frame with half mortise hinges (no pressed steel frame).

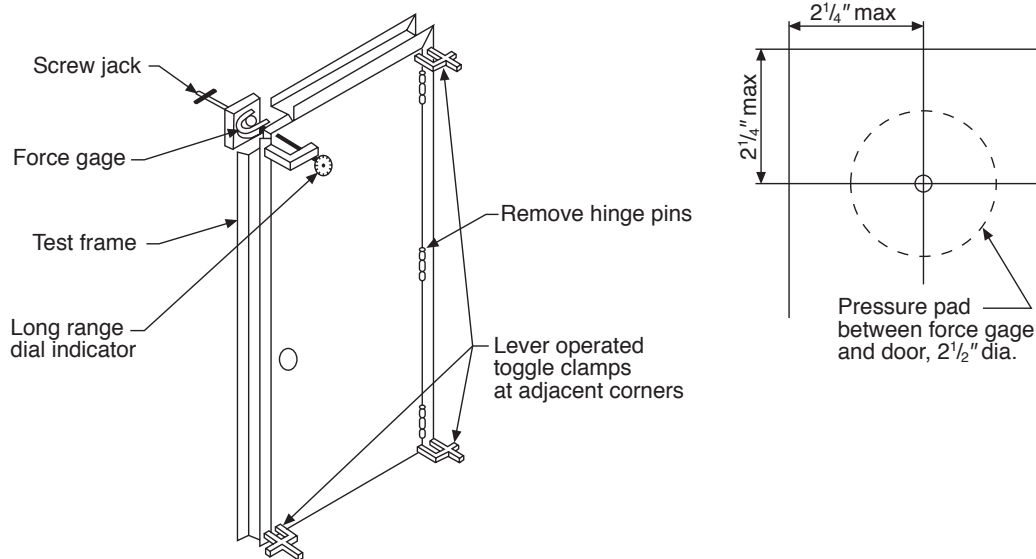

Figure 2 – Twist test

clips and screws, corner tabs and slots, head and jamb tabs/slots hinge reinforcements, and strike reinforcements and shall cover the integrity of assembly methods used to connect the frame components

Door frames which have passed the cycling criteria at one level shall be deemed to have passed all lower levels. The results shall be recorded as part of the test report, Swing Test Form 2.

6 Twist test

The twist test is applicable in evaluating door construction only.

The deterioration of the door strength during the cycle test, if any, shall be checked through a series of twist tests. These twist tests shall be performed before the cycle test begins and then at 25,000 cycle intervals for the first 100,000 cycles and at 50,000 cycle intervals for the balance of the test.

During the twist test, the hinge pins and silencers shall be removed from the door and frame assembly and the exit device shall be unlatched. The door is then clamped in place as noted in figure 2. If necessary to facilitate twist testing, the door is permitted to be taken from the test fixture and installed in a separate twist fixture. Loads in 30 lb. increments shall be applied at the upper lock edge corner through the screw jack and force gage in the

area illustrated in figure 2. The deflection noted on the dial indicator shall be plotted against the load applied to the corner on Twist Test Form 3. A maximum 300 lb. load shall be applied. The load shall then be reduced in 30 lb. increments and corresponding deflections recorded and plotted on Twist Test Form 3. A smooth curve drawn through the points shall graphically demonstrate the reaction of the door to increasing and decreasing pressures at different cycle intervals.

At the completion of each twist test, the hinges shall be reassembled by means of inserting the hinge pins, silencers shall be reinstalled, the exit device shall be latched, and the assembly shall be subjected to another 25,000 or 50,000 cycles. The condition of the silencers shall be noted and replacements made where deemed necessary.

7 Acceptance criteria

7.1 Doors

7.1.1 Doors shall not show any visual indication of metal fatigue, cracking or deformation at hardware cutouts or along form contours.

7.1.2 Doors of laminated construction (cores laminated to face sheets, channels or stiffeners laminated to face sheets, etc.) shall not delaminate in excess of 10% of the total surface area.

7.1.3 In doors of welded construction (stiffeners or channels welded to face sheets, etc.) breakage of welds shall not exceed 10% of the total weld of those face stiffeners.

7.1.4 Top, bottom or edge channels shall remain securely in place, without any weld breakage.

7.1.5 Where seams occur on doors, there shall be no opening or spreading of the seam.

7.1.6 All hardware reinforcements shall remain securely in place and show no visual signs of metal fatigue, cracking or deformation.

7.1.7 As a result of the twist test, the maximum deflection permitted shall not exceed 2 ½" when loaded to 300 lb. for Level C. For Level B and Level A doors the maximum deflection shall not exceed 1 ¼" when loaded to 300 lb.

7.1.8 Permanent deflection for doors shall not exceed ⅛" when load is removed.

7.1.9 Tapped holes shall not strip.

7.1.10 At the completion of the swing and twist tests, the door shall be fully operable.

7.1.11 Upon completion of the foregoing checks and measurements, remove door from test structure and cut door into four equal sections with a

horizontal and a vertical cut at the center of the door height and door width. Internal construction of door shall be inspected visually for delamination, metal fatigue, cracking and weld failure. The results of this inspection shall be recorded in the test report.

7.2 Frames

7.2.1 Frames shall remain plumb, square, rigid, and show no visual signs of metal fatigue, cracking, or deformation at hardware cutouts or along form contours.

7.2.2 Corners shall stay aligned with seams in a closed position.

7.2.3 Perimeter clearances between door and frame shall not be greater than ⅛" from those listed at onset of test.

7.2.4 Hardware reinforcements shall remain securely attached to the frame, with all welds intact.

7.2.5 Tapped holes shall not strip.

7.2.6 At the completion of the test, the frame shall not limit door operation. If during the test the door becomes inoperable, it shall be determined whether a defective door frame, hardware reinforcement, hinge, frame anchor, etc., caused the failure and shall be so noted in the test report.

Performance Report — Swing Test Form 2

Date _____

Manufacturers _____

Test# _____

Jamb Width _____

Type and Size of Frame _____

Weight of Door _____

Type of Anchors _____

Inspection at indicated cycle intervals ⁽¹⁾	1 25 M	2 50 M	3 75 M	4 100 M	5 150 M	6 200 M	7 250 M	8 300 M	9 350 M	10 400 M	11 450 M	12 500 M	13 550 M	14 600 M	15 650 M	16 700 M	17 750 M	18 800 M	19 850 M	20 900 M	21 950 M	22 1000 M	
Condition of general appearance																							
Condition of perimeter clearance																							
Condition of strike prep.																							
Condition of hinge prep.																							
Top																							
Center																							
Bottom																							
Condition of mutes																							
Condition of wall anchors																							
Condition of floor anchors																							
Condition of miters																							

Level C Door ↑

Level B Door ↑

Level A Door ↑

⁽¹⁾ Indicates condition in appropriate columns:

S — Satisfactory

Use footnotes under Remarks for further explanation

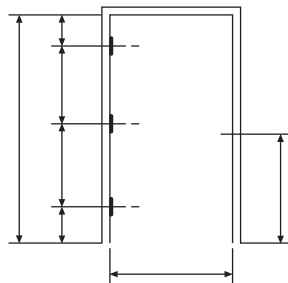

Hinge Manufacturer & Number _____

Lock Manufacturer & Number _____

Remarks:

Performance Report – Twist Test Form 3

Test No. _____ Date _____

Product Description _____

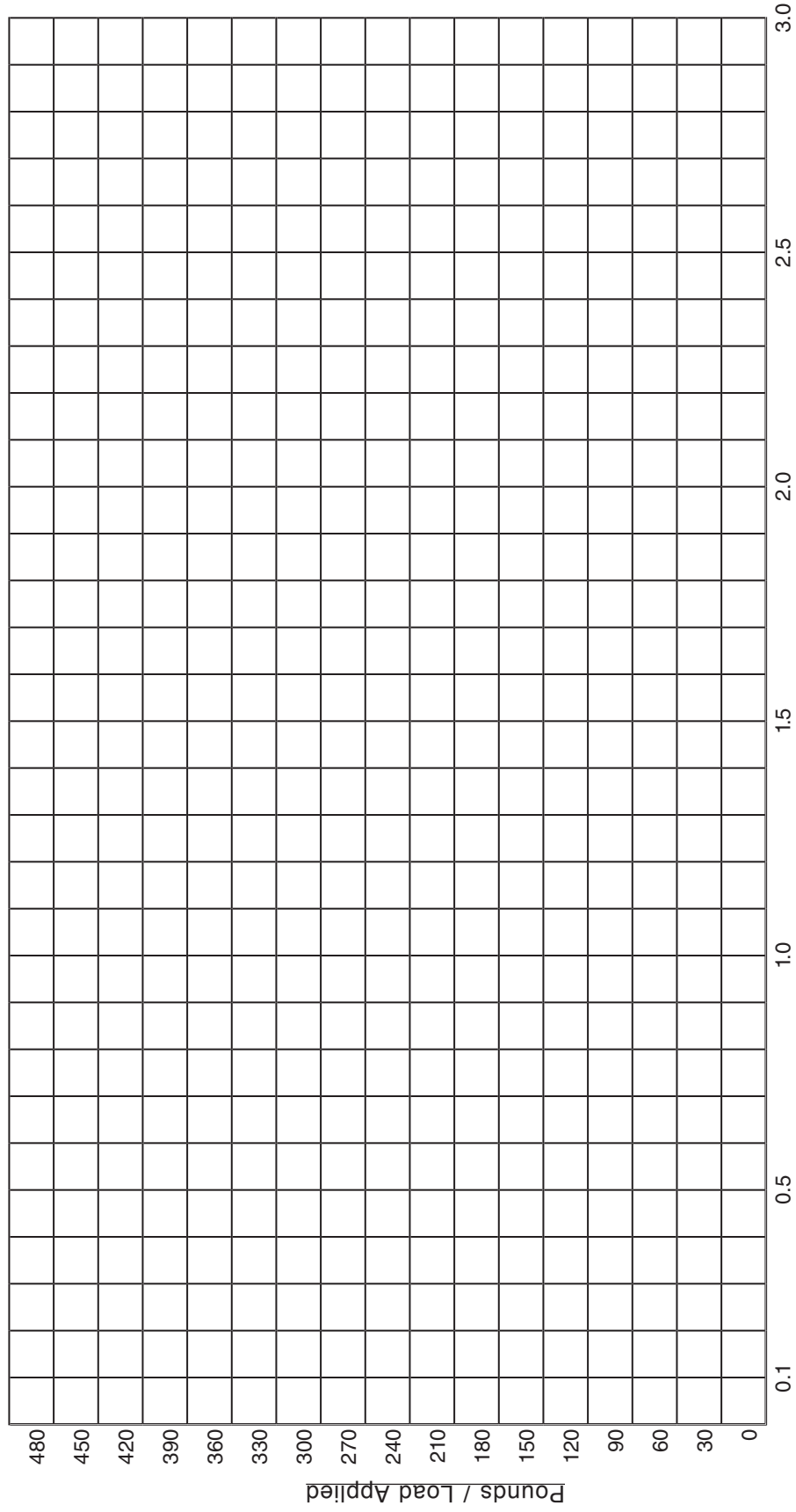

Inches / Deflection

AVAILABLE PUBLICATIONS

Specifications

- ANSI/SDI A250.6** Recommended Practice for Hardware Reinforcings on Standard Steel Doors and Frames
- ANSI/SDI A250.8** SDI 100 Recommended Specifications for Standard Steel Doors & Frames
- SDI-108** Recommended Selection & Usage Guide for Standard Steel Doors
- SDI-118** Basic Fire Door Requirements
- SDI-128** Guidelines for Acoustical Performance of Standard Steel Doors & Frames
- SDI-129** Hinge & Strike Spacing

Test Procedures

- ANSI/SDI A250.3** Test Procedure & Acceptance Criteria for Factory Applied Finish Coatings for Steel Doors & Frames
- ANSI/SDI A250.4** Test Procedure & Acceptance Criteria for Physical Endurance for Steel Doors, Frames and Frame Anchors
- ANSI/SDI A250.10** Test Procedure & Acceptance Criteria for Prime Painted Steel Surfaces for Steel Doors & Frames
- ANSI/SDI A250.13** Testing and Rating of Severe Windstorm Resistant Components for Swinging Door Assemblies
- SDI-113** Standard Practice for Determining the Steady State Thermal Transmittance of Steel Door & Frame Assemblies
- SDI-131** Accelerated Physical Endurance Test Procedure for Steel Doors, Frames and Frame Anchors

Construction Details

- ANSI/SDI A250.11** Recommended Erection Instructions for Steel Frames
- SDI-110** Standard Steel Doors & Frames for Modular Masonry Construction
- SDI-111** Recommended Details for Standard Details Steel Doors, Frames, Accessories and Related Components
- SDI-122** Installation & Troubleshooting Guide for Standard Steel Doors & Frames
- SDI** Drywall Slip-On Frames

Miscellaneous Documents

- ANSI/SDI A250.7** Nomenclature for Standard Steel Doors & Steel Frames
- SDI-112** Zinc-Coated (Galvanized/Galvannealed) Standard Steel Doors & Frames
- SDI-117** Manufacturing Tolerances for Standard Steel Doors & Frames
- SDI-124** Maintenance of Standard Steel Doors & Frames
- SDI-127** Industry Alert Series (A-L)
- SDI-130** Electrified Hinge Preparations
- SDI** What is The SDI?

AUDIO-VISUAL PROGRAMS ON VHS ALSO AVAILABLE



Standards As Tough As Steel.™

9/13/2011

MEMBERS OF THE STEEL DOOR INSTITUTE

AMWELD INTERNATIONAL, LLC

8324 Sterling Drive
Irving, TX 75063
(888) 775-2397
www.amweld.com

CECO DOOR PRODUCTS

9159 Telecom Drive
Milan, TN 38358
(731) 686-8345
www.cecodoor.com

CURRIES COMPANY

P.O. Box 1648
Mason City, IA 50402-1648
(641) 423-1334
www.curries.com

DEANSTEEL MANUFACTURING CO.

111 Merchant Street
San Antonio, TX 78204-1496
(210) 226-8271
www.deansteel.com

DOOR COMPONENTS INC.

7980 Redwood Avenue
Fontana, CA 92336-1638
(909) 770-5700
www.doorcomponents.com

MESKER DOOR, INC.

3440 Stanwood Boulevard
Huntsville, AL 35811-9021
(256) 851-6670
www.meskerdoor.com

METAL PRODUCTS, INC.

319 North Hills Road
Corbin, KY 40701
(606) 523-0173
www.metalproductsinc.com

PIONEER INDUSTRIES, INC.

171 South Newman Street
Hackensack, NJ 07601
(201) 933-1900
www.pioneerindustries.com

REPUBLIC

155 Republic Drive
McKenzie, TN 38201-0580
(731) 352-3383
www.republicdoor.com

SECURITY METAL PRODUCTS CORP.

5700 Hannum Avenue, Suite 250
Culver City, CA 90230
(310) 641-6690
www.secmet.com

STEELCRAFT

Ingersoll Rand Security Technologies
9017 Blue Ash Road
Cincinnati, OH 45242
(513) 745-6400
www.steelcraft.com

STEEL DOOR INSTITUTE

30200 DETROIT ROAD • CLEVELAND, OHIO 44145

440.899.0010 • FAX 440.892.1404

www.steeldoor.org